



lead forming machines

selective soldering machines

special machines



Internet: <http://www.ebso.com>



EBSOMAT 400

Um eine Machbarkeit Ihrer Anwendung zu prüfen bitten wir Sie uns Folgende Informationen mitzuteilen.

Eine Zeichnung der Biegung mit Angabe der folgenden Maße.

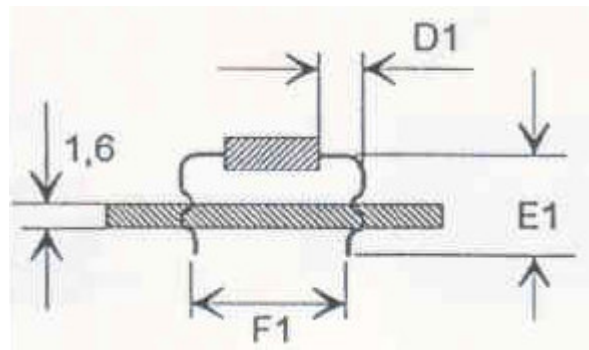
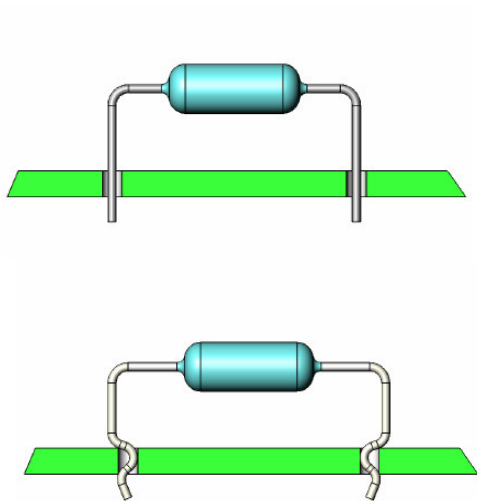

LP-Dicke Standard = 1,6 mm
Wenn abweichend bitte angeben

Drahtdurchmesser und Bauteil
spezifikationen

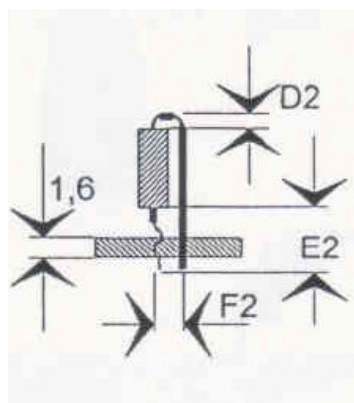
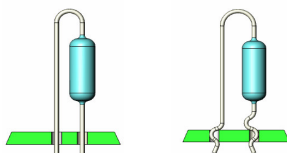
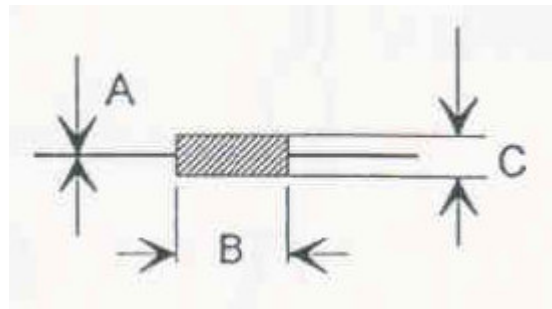



lead forming machines

selective soldering machines

special machines

EBSO

Internet: <http://www.ebso.com>



Angaben zum Bauteilgurt

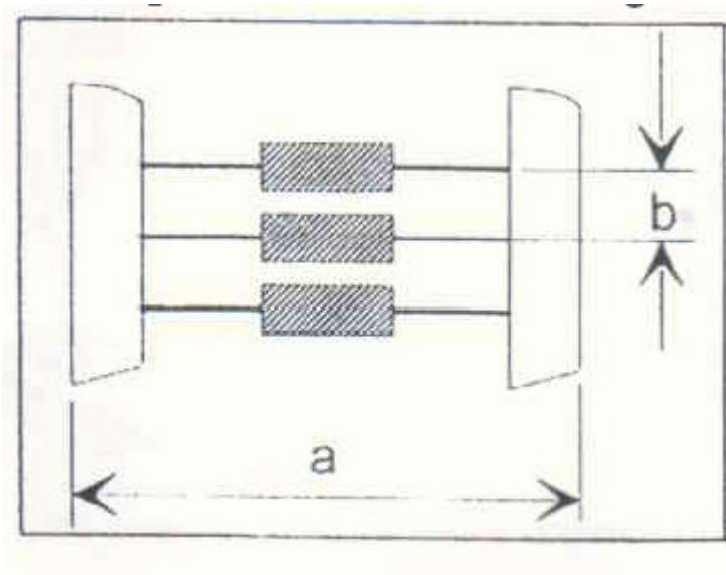



lead forming machines

selective soldering machines

special machines



Internet: <http://www.ebso.com>



Folgend sind Beispiele von Werkzeugformen abgebildet mit den dazugehörigen Werkzeugnummern.

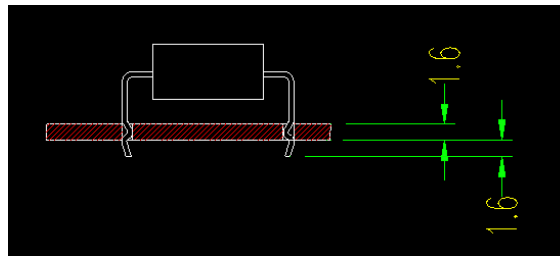

4-001

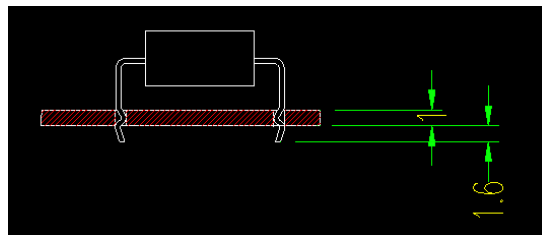

4-011

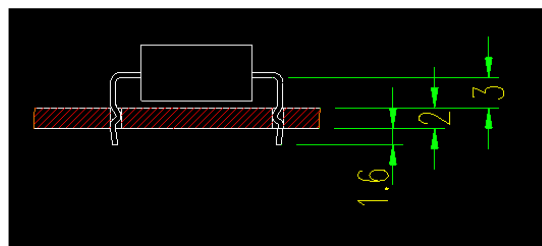

4-066





lead forming machines

selective soldering machines

special machines

EBSO

Internet: <http://www.ebso.com>

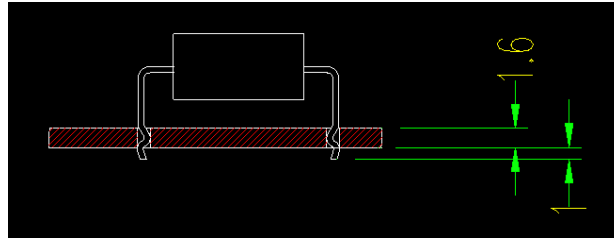

4-026

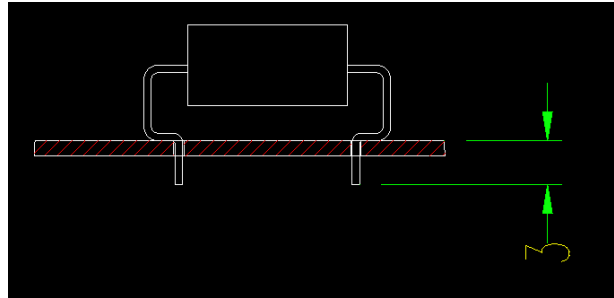

4-006

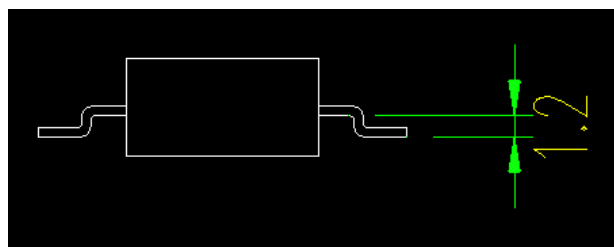

4-006





lead forming machines

selective soldering machines

special machines



Internet: <http://www.ebso.com>

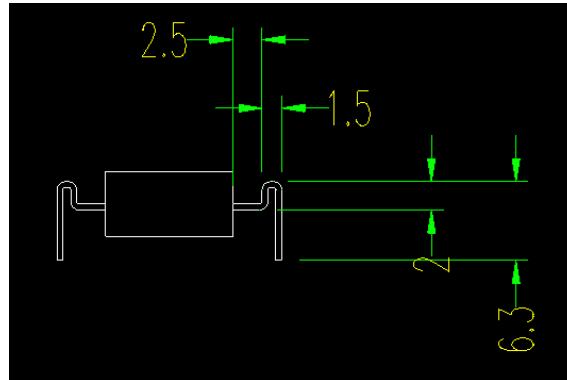

4-046

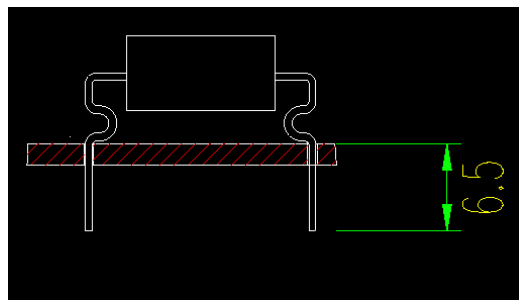

4-059

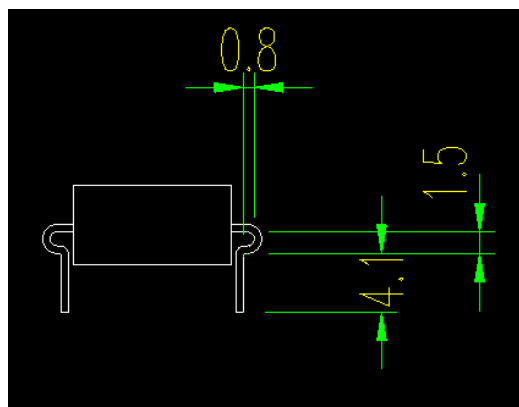

4-067

